

ERITECH[®]

ERITECH[®] Isolated Downconductor

Isolated Lightning Protection Using
IEC 62305 Separation Distances

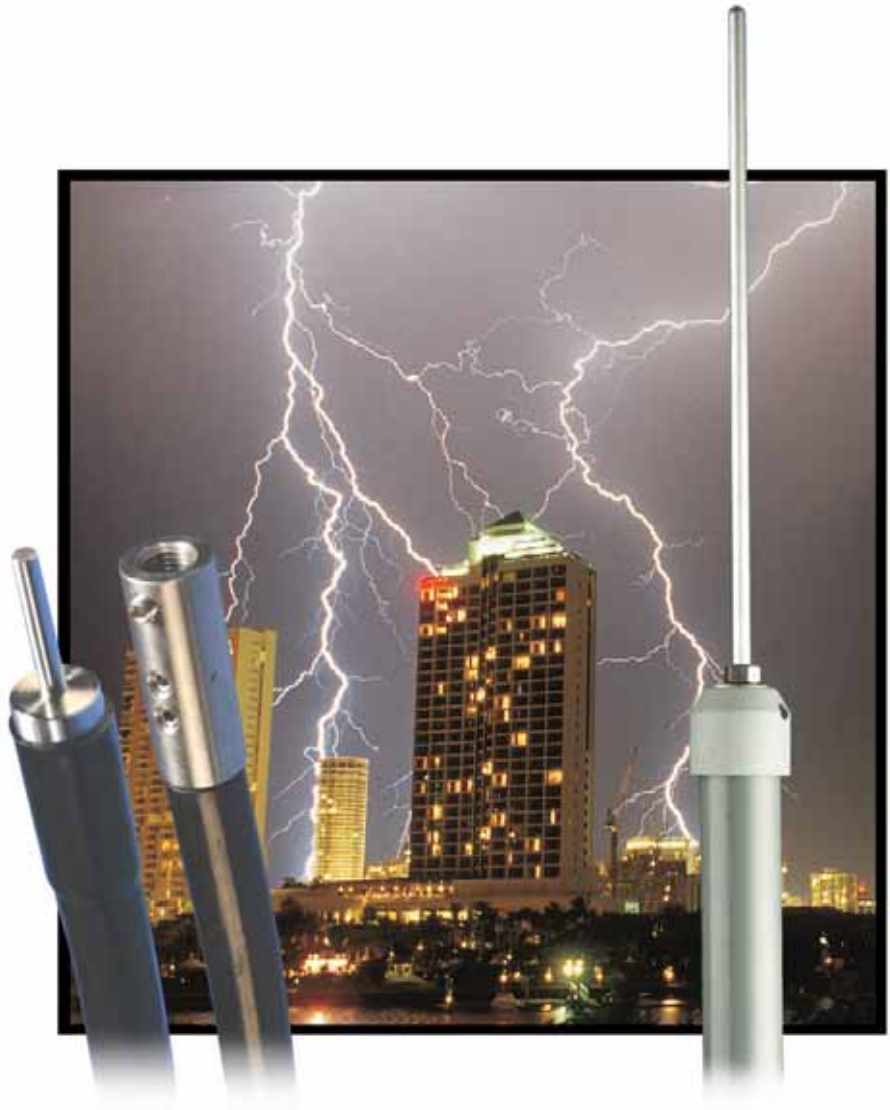

ERICO[®]

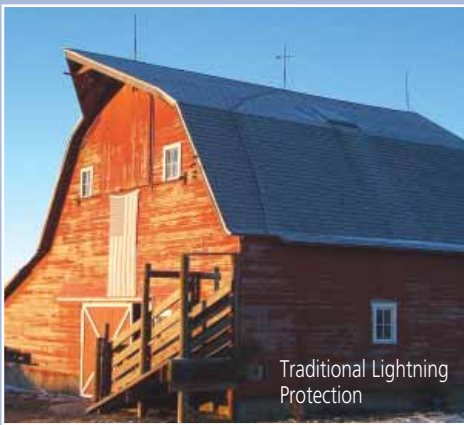

Traditional Lightning Protection

Traditionally structures have been protected by the use of air terminals (Franklin Lightning Rods) and a network of downconductors connecting to an integrated grounding system. However the modern building often contains roof top mounted heating/cooling systems and an array of communication antenna. The traditional building lightning protection techniques are not well suited to protection of these modern roof top devices. With the possibilities of very large currents being conducted by the lightning protection system, the close proximity of this electrical and electronic equipment is of concern. The bonded equipment frames, masts and cable sheaths can form part of the lightning discharge path, and damage can result.



Typical rooftop telecommunications equipment

Thankfully the IEC Lightning Protection Standards provide two approaches to protection, the traditional bonding of metallic items in order to minimize potential differences, or the use of an isolated system where the lightning protection system is insulated from the structure/equipment. Generally insulated brackets are used to hold the air terminals and downconductors 300-1000 mm off the structure. While offering a technical advantage the appearance, complexity and cost of such solutions limits their use. For the telecommunication industry mounting a second taller mast to protect the first is not a practical solution.

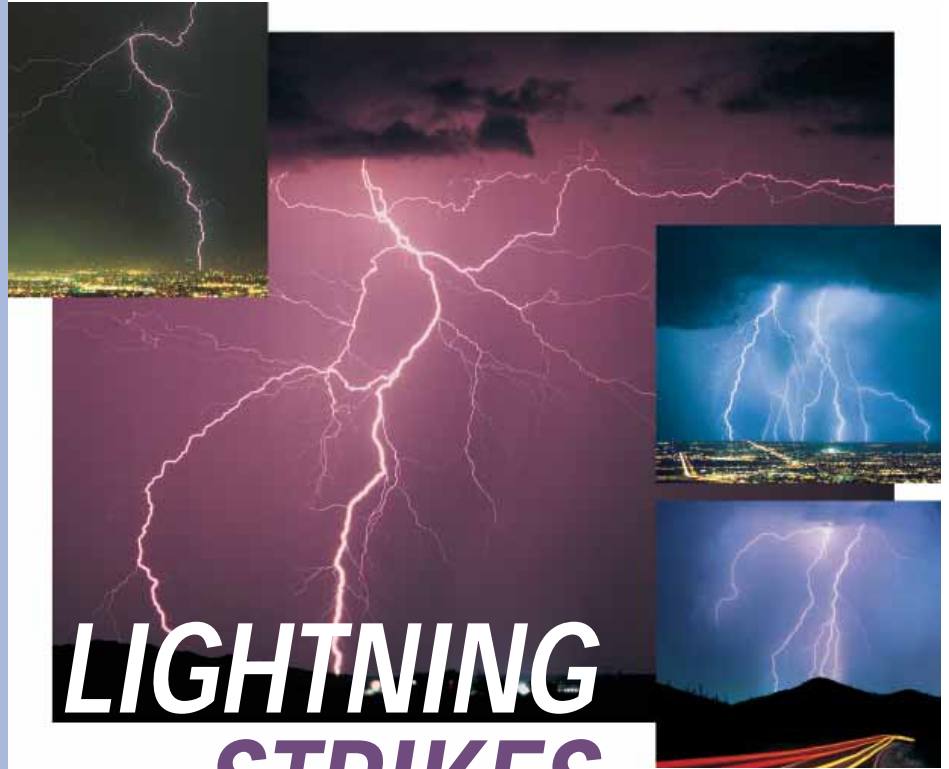

LIGHTNING STRIKES

again and again and again...

ERICO®, with its 25 years of experience in the development of a diverse range of lightning protection solutions, now solves this problem with the ERITECH® Isolated Downconductor. By applying a high performance insulation around the downconductor, the same isolation as 1000 mm of air separation can be provided. The advantage is that this downconductor can be mounted directly on the mast or structure to be protected – without electrification!



Illustrators representation of installed ERITECH Isolated Downconductor system

ERITECH® ISOLATED DOWNCONDUCTOR

Since ERICO® offered its first isolated downconductor, thousands of buildings have proven this concept. The pioneering use of semi-conductive external outer sheath to bond to the structure and control cable break down was a key to success. The original implementation (ERITECH® ERICORE) was a screened cable version designed for low impedance, this

allowed the use of very long cable lengths. The latest ERITECH® Isolated Downconductor customizes this development by offering a lower cost cable targeted at the typical shorter installation requirements of the telecommunication industry. The cable is designed, tested and applied to meet the requirements of IEC 62305 lightning protection standards.

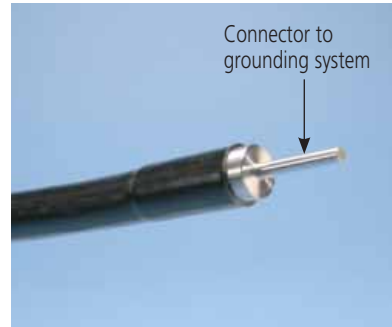
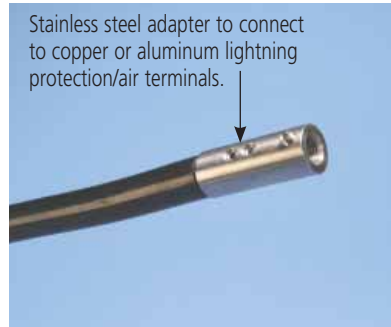
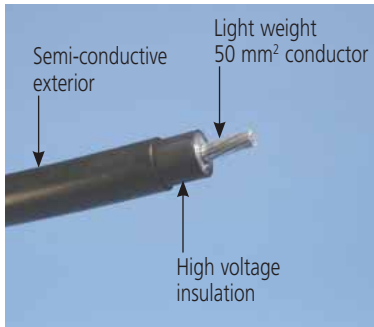

ERITECH Isolated Downconductor low cost cable

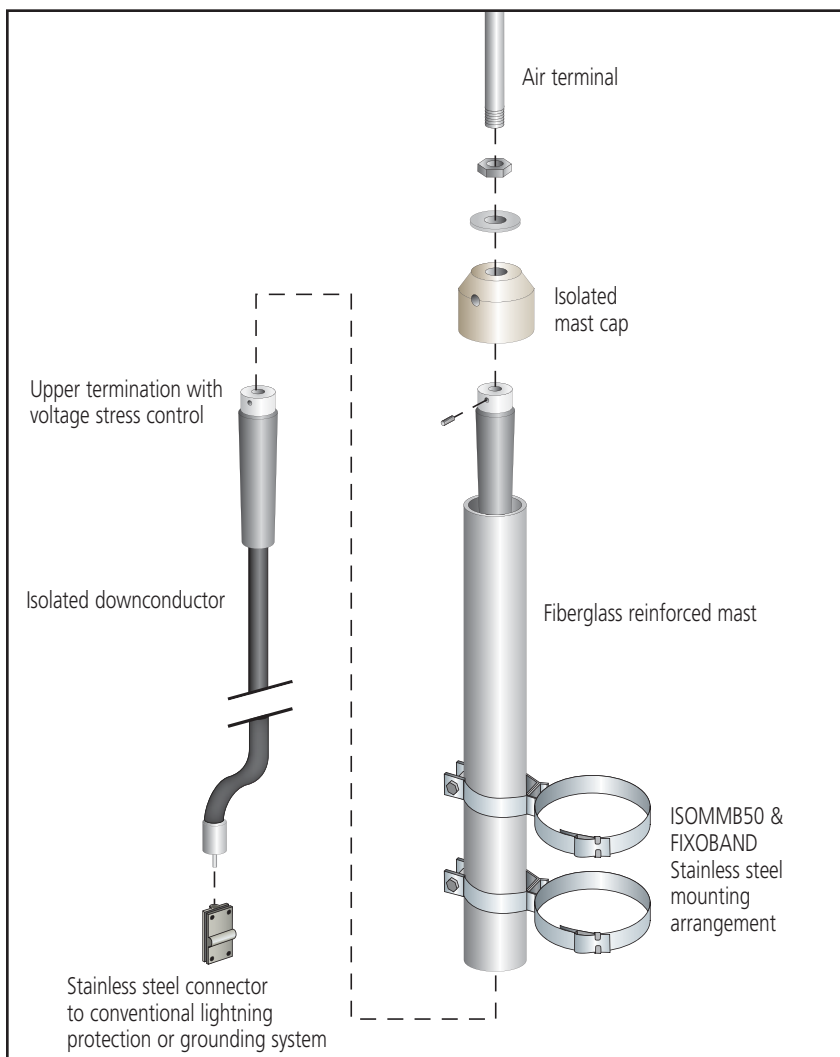

ERITECH Isolated Downconductor

What is the ERITECH Isolated Downconductor system?

The ERITECH isolated system provides a traditional air terminal fitted to an isolated fiberglass reinforced plastic (FRP) mast. The isolated downconductor internally connects to the air terminal inside the FRP. The FRP mast has natural isolation properties, high strength for windy sites and low weight to minimize mast loading.

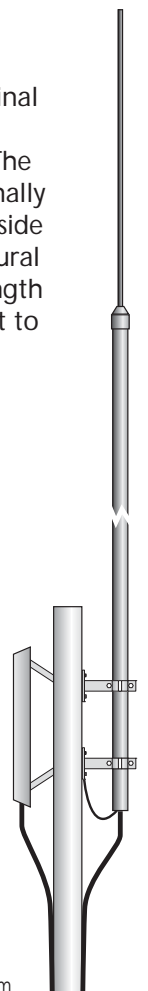

Design and Application

Implementation of the ERITECH® Isolated Downconductor system is based on two sections of the IEC 62305-3 standard (Protection Against Lightning – Part 3: Physical damage to structures and life hazard). For correct installation the system must be designed and installed in accordance with these requirements:

Step 1) Determine the required height of the air terminal to provide protection according to IEC 62305 Protection Angle Method (PAM)

The required lightning protection level can be determined by IEC 62035-2 Risk Assessment, or simply using LPL I for maximum protection.

Using this information the designer should determine the required minimum height of the air terminal tip above the top of mast/items to be protected. (**Note:** ERITECH Isolated Downconductor mast requires a minimum clearance distance of 2 m).

Step 2) Determine the length of downconductor and selected lightning protection level so the separation distance (IEC 62305-3 Section 6.3) does not exceed 1000 mm. (Refer to **page 5**)

Step 3) Meet ERICO's mounting and installation requirements and interconnect to a standard compliant grounding or lightning protection system.

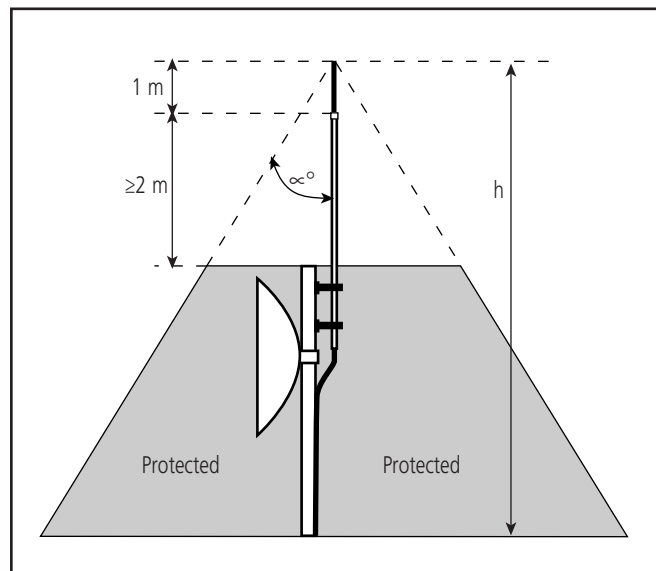

Protected angle

IEC 62305 Part 3, details the protection angle

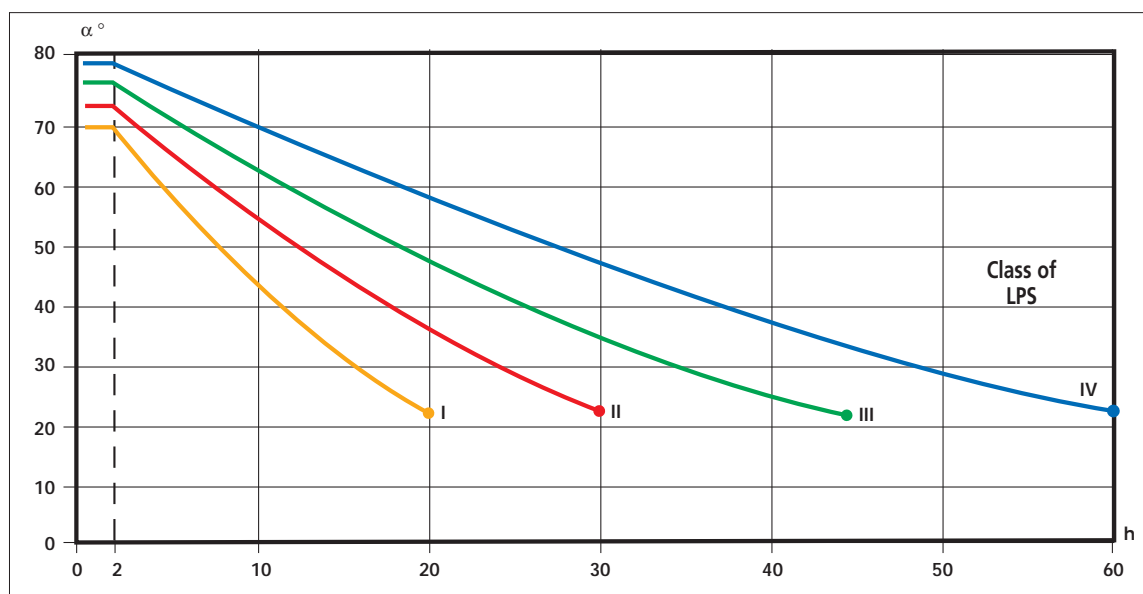

	Lightning Protection Level (Class of LPS)	Peak Current (10/350 μs)	Probability of Exceedance
●	I	200 kA	≤ 1 %
●	II	150 kA	≤ 3 %
●	III	100 kA	≤ 9 %
●	IV	100 kA	≤ 16 %



IEC 62305 Electrical Insulation and Separation Distance

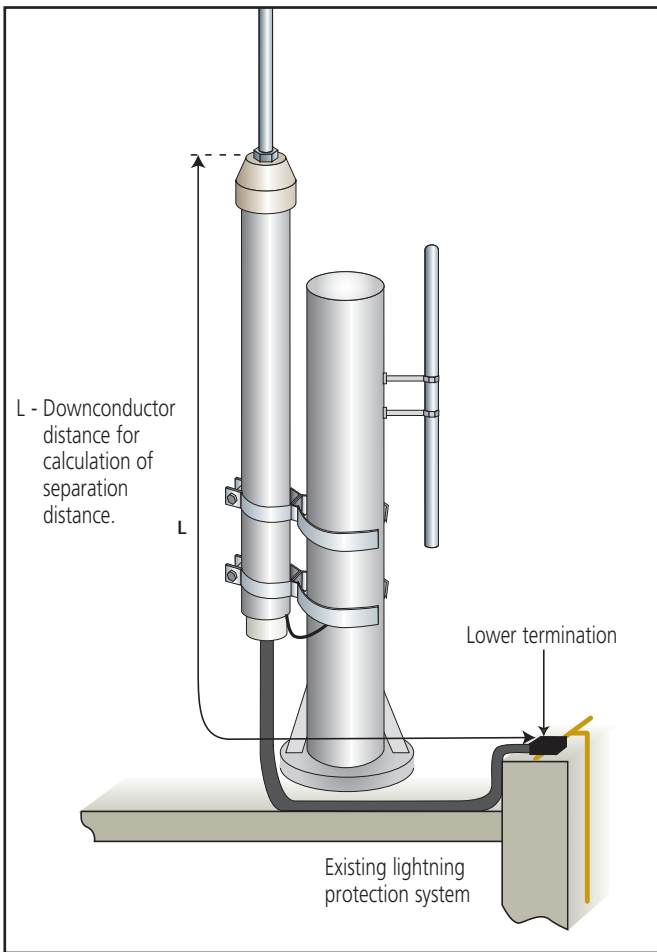

Equipment and structures can be protected by isolation, provided that the distance between the air terminal (or downconductor) and items to be protected are separated by a separation distance greater than:

$$S = k_i \frac{k_c}{k_m} l$$

IEC 62305-3 Section 6.3, equation 4

Where:

k_i depends upon the selected class of LPS

k_c depends upon the lightning current flowing on the downconductors ($k_c = 1$ for a single downconductor)

k_m depends upon the electrical insulation material ($k_m = 1$ for air)

l is the length, in meters, along the downconductor (from nearest equipotential bonding point, i.e. normally from lower termination), to the point where the separation distance is being considered.

	Class of LPS (LPL Lightning Protection Level)	k_i
●	I	0.08
●	II	0.06
●	III	0.04
●	IV	0.04



Illustrators representation of a strike

The ISODC Isolated Downconductor has an equivalent separation distance of 1000 mm of air. Therefore simplifying the above equation, the table provides the maximum length for a single downconductor where the lower termination is equipotentially bonded to the structure.

	Class of LPS (Lightning Protection Level)	Maximum Isolated Downconductor Length
●	I	12.5 m
●	II	16.6 m
●	III	25 m
●	IV	25 m

Maximum Isolated Downconductor length for single equipotential bonded cable

Where the lower termination is not equipotentially bonded to the structure, such as when connected to an isolated ring system, then distance must be measured to the nearest LPS-structural equipotential point. Contact ERICO® for assistance.



ISODUAL Dual Coupling

If the maximum cable limitations above can not be adhered to, then it is possible to use two parallel downconductors. The ISODUAL adapter allows a second isolated downconductor to be connected to the air terminal. The second ISODC Downconductor is mounted externally to the Isolated Mast and fixed with UV stable non conductive cable ties.

TESTING & CERTIFICATION

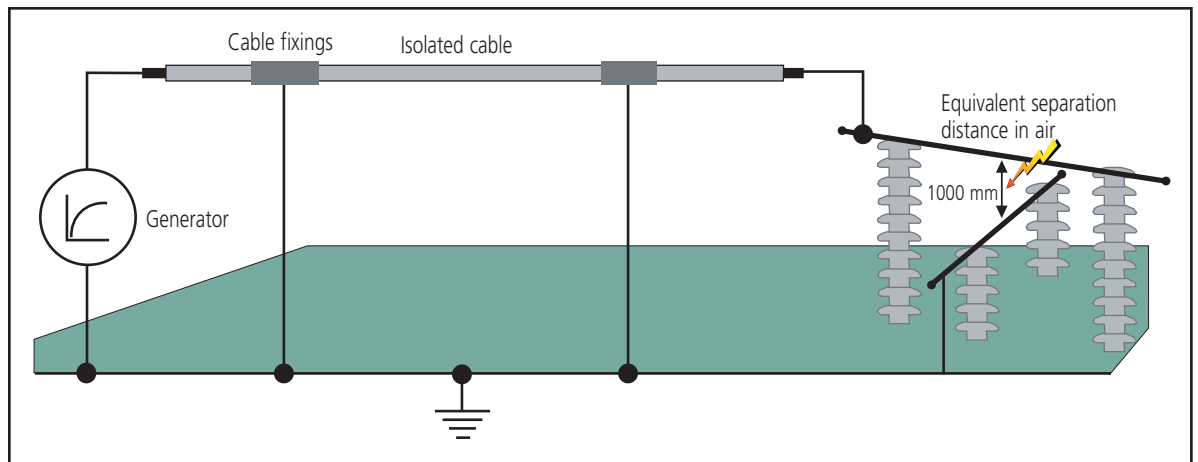

Test lab setup for determining equivalent separation distance



ERITECH Isolated Downconductor being tested

The isolated lightning protection detailed in IEC 62305 for the protection of structures and equipment is based on ensuring adequate air separation is provided of a bare downconductor from the object to be protected. This distance is known as the "separation distance" (Additional distance factors are given for concrete and brick separation).

The ERITECH® Isolated Downconductor has been successfully tested by an independent laboratory using the industry accepted "Zischank" method*. Here a length of cable is tested with voltage impulses in comparison to an air gap. If the parallel air gap breaks down repeatedly before the cable, then the equivalent safety distance of the cable is greater than the air gap distance.

All ERITECH Isolated Downconductor system components meet the requirements of IEC 62305 series and appropriate products are tested in compliance with EN 50164-1 and EN 50164-2.



Telecommunication tower

 Fachhochschule Kiel, University of Applied Sciences Institute of Electrical Power Engineering High Voltage Technology and EMC	1	
<h2 style="margin: 0;">Test Report</h2> <h3 style="margin: 0;">B-07-19-ERI-005e</h3> <p style="margin: 10px 0 0 0;"><u>Investigation of the separation distance of an isolated down-conductor</u></p> <p style="margin: 20px 0 0 0;"> Fachhochschule Kiel University of Applied Sciences Kiel Laboratory of High Voltage Technology and EMC Grenzstraße 5 D-24149 Kiel Phone: + 49-431-210-4060 Fax: : + 49-431-210-4070 </p> <p style="font-size: small; margin: 10px 0 0 0;"> Prof. Dr.-Ing. Klaus Scheibe, Kiel, 06. February 2007 Dipl.-Ing. Eberhard Lehmann, Kiel, 06. February 2007 </p>		

The ERITECH Isolated Downconductor test reports

* W. Zischank "Insulators for isolated or partially isolated lightning protection system to verify safety distances" 23rd International Conference on Lightning Protection (ICLP), Firenze (1996), S 513-518.



ERITECH® ISOLATED DOWNCONDUCTOR



AIR TERMINAL

AAR0515 (#710020) 500 mm 0.25 kg
AAR1015 (#711070) 1000 mm 0.53kg

Aluminum air terminal, 16 mm diameter.



CABLE TIE

CABTIE-SS (#701420)
Stainless Steel Cable Tie 0.05 kg

520 mm stainless steel cable tie for securing downconductor.



ISOLATED MAST CAP

ISOCAP50 (#702086) 0.1 kg

Fits to top of ISOFRP3M mast for mounting of air terminal.

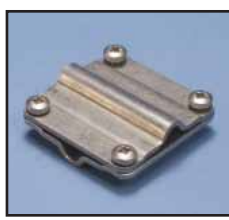

MULTIPURPOSE CLAMP

CCS-308 (#545170) Stainless Steel Clamp 0.15 kg

For connection of lower termination to 25x3 mm, 30x2 mm or 8-10 mm diameter lightning protection or grounding systems.



ISOLATED MAST

ISOFRP3M (#702087) 4.2 kg

3 m fiber glass mast, 50 mm diameter.



LIGHTNING EVENT COUNTER

LEC-IV (#702050) Lightning Event Counter 2.0 kg

Installed upon downconductor to record number of lightning strikes.



ISOLATED MAST BRACKET

ISOMMB50 (#702088) 0.4 kg

For mounting ISOFRP3M. Use 20 mm stainless steel Fixoband to allow mounting on virtually any mast type/diameter.

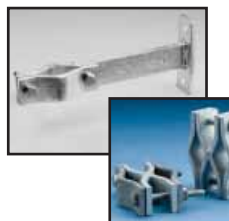

MAST BRACKET

ALOF-1-GS (#702175) 1.5 kg
Galvanized mast bracket providing 190 mm offset.

ACF-2-GS (#103100) 2.1 kg
Galvanized x mast bracket



ISOLATED DOWNCONDUCTOR

ISODC 0.58 kg/m

Supplied with factory upper termination fitted and materials for customer lower termination. Order required length in meters.



DUAL DOWNCONDUCTOR ADAPTOR

ISODUAL (#702094) 0.2 kg

For connecting second parallel ISODC for increased safety distance.



CABLE SADDLE AND SCREWS

2HPS (#400680) Saddle 0.02 kg

CONSAD/FX (#701410) Screw 0.01 kg

Galvanized steel cable saddle and stainless steel screws for securing ISODC.



FIXOBAND

42014 (#591290)
Fixoband Tool 1.8 kg



FEI20 (#591230)
Stainless Steel Strap 20 mm 0.1 kg



CEI20 (#591080)
Stainless Steel Buckle 0.01 kg

Strapping materials and tools for installation of mast mounting bracket ISOMMB50.

ERICO® offer a large range of products for lightning and grounding applications. Please contact us should you require additional materials.

ERICO®



www.erico.com



AUSTRALIA

6 Chilvers Road
P.O. Box 148
Thornleigh (Sydney) NSW 2120
Australia
Phone 61-2-9479-8500
Fax 61-2-9484-9188



GERMANY

66851 Schwandenmühle
Germany
Phone 49-6307-918-10
Fax 49-6307-918-150



POLAND

ul. Krzemieniecka 17
54-613 Wrocław
Poland
Phone 48-71-374-40-22
Fax 48-71-374-40-43



BELGIUM

Postbus 33
3110 Rotselaar
Belgium
Phone 32-14-69-96-88
Fax 32-14-69-96-90



HONG KONG

Unit 1, 2nd Floor, Block A
Po Yip Building
62-70 Texaco Road
Tsuen Wan, New Territories
Hong Kong
Phone 852-2764-8808
Fax 852-2764-4486



SINGAPORE

Jurong Industrial Estate
16 Wan Lee Road
Singapore 627 946
Phone 65-6-268-3433
Fax 65-6-268-1389



BRAZIL

R. Dom Pedro Henrique de Orleans
E Braganca, 276
Vila Jaguara
São Paulo CEP 05117-000
Brazil
Phone 55-11-3621-4111
Fax 55-11-3621-4066



HUNGARY

P.f. 184
1476 Budapest
Hungary
Phone 31-13-58-34-547
Fax 31-13-58-35-499



SPAIN

C/Provenza 288, Pral.
08008 Barcelona
Spain
Phone 34-93-467-7726
Fax 34-93-467-7725



CANADA

P.O. Box 170
Mississauga, Ontario
Canada L5M 2B8
Phone 1-800-677-9089
Fax 1-800-677-8131



INDONESIA

Sampoerna Strategic Square,
Tower B 19th Fl.
Jalan Jend. Sudirman Kav. 45-46
Jakarta 12930
Indonesia
Phone 62-21-575-0941
Fax 62-21-575-0942



SWEDEN

Box 211
201 22 Malmö
Sweden
Phone 46-40-611-13-60
Fax 46-40-611-94-15



CHILE

Alcantara 200, piso 6 Of. 17
Las Condes, Santiago
Chile
Phone 56-2-370-2908
Fax 56-2-370-2914



ITALY

A&B Business Center
Via Valla 16, nr. 17
20141 Milano
Italy
Phone 39-02-8474-2250
Fax 39-02-8474-2251



SWITZERLAND

Postfach 54
3280 Murten
Switzerland
Phone 00-800-5000-1090
Fax 00-800-6000-1090

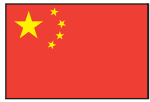

CHINA

Room 1204
Tomson Commercial Building
No. 710 Dongfang Road
Pudong, Shanghai
P.R. China 200122
Phone 86-21-5081-3900
Fax 86-21-5831-8177



MEXICO

Melchor Ocampo 193
Torre A piso 13
Col. Veronica Anzures
11300 Mexico D.F.
Mexico
Phone 52-55-5260-5991
Fax 52-55-5260-3310



THAILAND

163 Ocean Insurance Bldg.
16th Fl. Unit B
Surawongse Road
Bangrak Bangkok 10500
Thailand
Phone 66-2-634-1692
Fax 66-2-634-1694



DENMARK

Box 211
201 22 Malmö
Sweden
Phone 46-40-611-13-60
Fax 46-40-611-94-15



NETHERLANDS

Jules Verneweg 75
5015 BG Tilburg
Netherlands
Phone 31-13-58-35-400
Fax 31-13-58-35-499



UNITED KINGDOM

52 Milford Road
Reading, Berkshire RG1 8LJ
United Kingdom
Phone 44-118-955-0900
Fax 44-118-955-0925



FRANCE

rue Charles Dallière, BP 31
42161 Andrezieux Bouthéon Cedex
France
Phone 33-4-77-36-54-32
Fax 33-4-77-55-20-10



NORWAY

Postboks 148
1366 Lysaker
Norway
Phone 47-67-53-12-00
Fax 47-67-12-42-68



UNITED STATES

34600 Solon Road
Solon, Ohio 44139
U.S.A.
Phone 1-440-248-0100
Fax 1-440-248-0723